

Jindara[®]

Heating

A division of A.F. Gason Pty. Ltd.



Hamersley MK2 Freestanding

Operation & Installation Instructions

RevA

Please keep these instructions for future reference.

235798



Read and follow these instructions carefully before installing and using this appliance

SAVE THESE INSTRUCTIONS



Safety Warnings

- A flue fire with resulting damage may occur if the appliance is not installed, operated and maintained as per this booklet.
- Never place combustible materials such as wood, paper or furniture near the appliance.
- This appliance is designed to burn dry hardwood. Do not burn rubbish, driftwood, flammable liquids or any substance containing salts or corrosives.
- This appliance must not be installed and operated in an area where kerosene, petrol, paint thinner or other flammable liquid is used or stored.
- The flue system must be inspected and cleaned annually or sooner if required. Failure to do so could result in an excessive build up of creosote which may result in a flue fire which may damage the flue or cause damage to your home.
- The surface of the appliance becomes hot during operation. Do not touch the surface of this appliance. Keep children away from this appliance during operation. Do not allow anyone to operate this appliance who is not familiar with this instruction booklet.



Paint Curing and Care

Your heater is coated with the best available heat resistant paint. Even though the paint has been baked after application, it may require further temperature curing. It may, if you overfire the heater on its first fire, discolour. For your first two or three firings, never exceed the medium air setting and always have the fan on when above low burn. Do not wipe the heater while the paint is curing. After the paint has cured the only maintenance required to maintain the heater's finish is to wipe it with a soft cloth. Do not use any commercial cleaners or solvents on the paint finish.

We are proud of the presentation of our products. If at any time you need to freshen up the paint, your local dealer has touch up paint available for purchase. You may even change the colour of your heater if you wish.

If you have any enquiries, please contact the dealer from whom you purchased your heater:

PLEASE COMPLETE:

Dealer Name

Dealer Address

Phone:

Please attach your original purchase dockets to this booklet for future reference.

Installation



WARNING

Installation

THE INSTALLATION OF THIS APPLIANCE MUST BE CARRIED OUT AS PER THIS MANUAL AND THE FLUE MANUFACTURER'S SPECIFICATIONS.

WE RECOMMEND THAT YOU USE A QUALIFIED INSTALLER TO CARRY OUT THE INSTALLATION.

If you have any other enquiries, please contact the dealer from whom you purchased your heater.

THIS APPLIANCE WEIGHS IN EXCESS OF 190 KILOGRAMS. EXTREME CARE SHOULD BE TAKEN WHEN HANDLING THE APPLIANCE.

A.F. Gason Pty. Ltd. accepts no liability whatsoever for interpretation of AS/NZS 2918:2001

It is important you understand these installation instructions and minimum clearances to combustible materials before selecting a position for your Jindara Hamersley to ensure safe and correct installation is achieved.

Installation Permit

Depending on your local authority requirements, a permit may be required for the installation of your heater. It is your responsibility to arrange for these requirements to be met.

Clearances

All dimensions used in this document are in millimetres and are minimum unless otherwise stated. These dimensions state the minimum distance the Jindara Hamersley can be placed in relation to any combustible materials - plaster, wallpaper, timber, MDF, etc.

In the instance your Jindara Hamersley is surrounded by non-combustible materials – brick, stone, concrete, cement sheet, Villaboard or similar, wall clearances can be reduced to 100mm. A 100mm clearance is required, to ensure room air can circulate around the wood heater during operation.

The Jindara Hamersley freestanding heater conforms to AS/NZS 2918:2018 when positioned in relation to combustible surfaces as shown in the graphic on the following page.

For additional clearance details, please contact the Jindara dealer from whom you purchased your heater.

Hearth requirements

If the Jindara Hamersley will be installed onto a non-combustible floor such as stone, a concrete slab with tiles, brick, etc. with a thickness of at least 24mm, extending at least 530mm in front of the appliance base, a hearth or floor protector may not be required.

If the Jindara Hamersley is to be installed onto a combustible floor, a minimum 24mm cement sheet or similar non-combustible hearth or floor protector must be placed on top of the combustible floor. At a minimum, the floor protector must extend 530mm in front of the appliance base. The protector must be at least 1000mm wide (central to the appliance) and 1100mm deep. If desirable, the floor protector can extend further, to meet the skirting boards or walls at the rear of the appliance, when installed as per the wall clearances.

For details please refer to the diagrams on the next page.

Installation (continued)

• Installation Clearances

Your Jindara Hamersley has been tested in accordance with AS/NZS 2918:2018 for standard and for corner installations. The below table and figures highlight the minimum allowable clearances for three different flue configurations. For each configuration a minimum 24mm thick compressed board floor protector shall be used under the appliance per the below dimensions.

- 1) **6" Triple Flue Kit:** 6" stainless default Flue kit with 8" painted decromesh outer flue casing which extends from the top of the heater to the drop box at the ceiling level.
- 2) **6" Triple Flue Kit with half shield** - as above with an additional stainless half shield 1610mm high 180° fitted between the active flue and decromesh
- 3) **Double Sleeve Flue Kit** - 6" stainless default flue kit extending up to the drop box at ceiling level with a 180 degree 900mm stainless half shield spaced of the rear of the first length of active flue.

	6" Triple Flue kit	6" Triple Flue kit with half shield	Double Sleeve Flue Kit
A	1000mm	1000mm	1000mm
B	530mm	530mm	520mm
C	24mm	24mm	
D	1322mm	1172mm	1187mm
E	125mm	125mm	125mm
F	450mm	450mm	475mm
G	250mm	100mm	125mm
H	790mm	790mm	790mm
I	200mm	50mm	225mm
J	1582mm	1432mm	1600mm
K	875mm	725mm	893mm
L	451mm	301mm	326mm
M	867mm	655mm	902mm

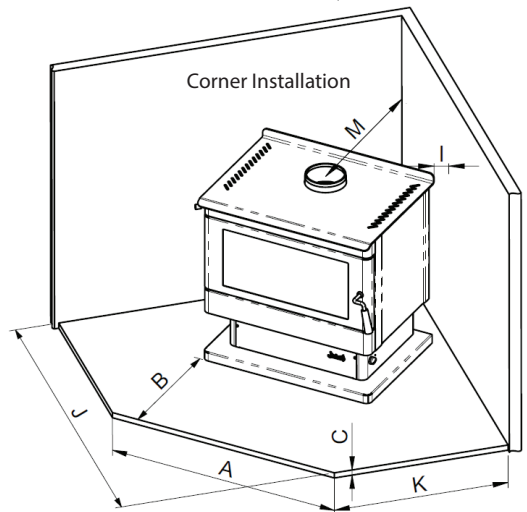
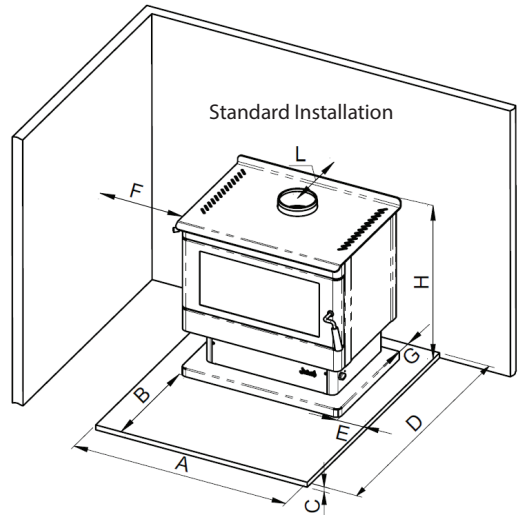

Installation (continued)

Flue Installation

The flue system must comply with Australian and New Zealand installation standards AS/NZS 2918:2001, and be installed to the flue manufacturer's instructions.

The performance of your Jindara Hamersley is highly reliant on an effective flue system. In many cases poor start-up, dirty glass, down draft which causes smoking when door is open, and a reduction in heat output can all be related to the flue being too short, or incorrect installation. Too tall a flue can result in excess draft and short burn times along with excessive heat output.

Fitting the Baffle Plate

1. Feed the baffle plate through the door opening with front edge folded up, feeding plate all the way to the rear of the heater.
2. Lift front over Pin A and slide towards front of heater.
3. Lift rear so the baffle plate is horizontal and move towards back of the heater.
4. Lower over Pin B.
5. Baffle plate must be sitting on Pins A & B.

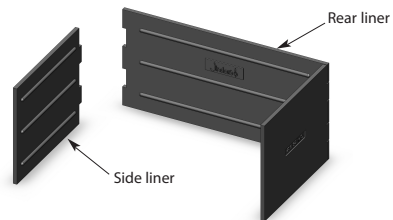

Placement of Cast Iron Liners into firebox

The rear cast iron liner is to be positioned to the rear with rib and logos facing into the firebox. Side cast liners are to be positioned on the appropriate side and interlock into the rear cast liner. Fire bricks can then be installed.

Placement of Fire Bricks into firebox

Fire bricks must be sitting flat on the bottom of the firebox, covering base.

Placement of Ash Deflector into firebox

After cast iron liners and fire bricks are fitted correctly into position, slide ash deflector in between the cast plates and down in front of the bricks. The deflector should be positioned such that the 100mm leg is placed within the firebox, and the 50mm leg faces towards the door to prevent ash build up on the door.

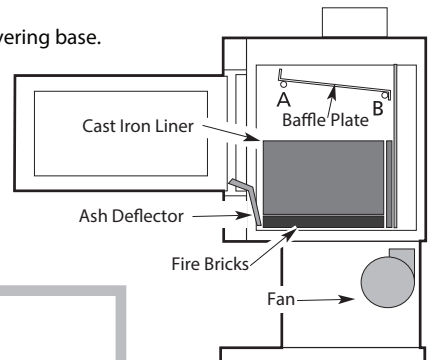

Final inspection prior to use

- Ensure the baffle plate is firmly located.
- Ensure cast iron liners - side and back - are positioned correctly.
- Ensure fire bricks are sitting flat and covering entire base.
- Ensure ash deflector is positioned correctly.
- Check fan cord has not been damaged during transit.
- Plug in fan cord and ensure cord does not touch stove surface.
- Check all door seals are fitting correctly.

Installation (continued)

Flue and chimney requirements

The flue pipe shall extend not less than 4.6m above the top of the floor protector. Note: Installation must be carried out by a licensed installer in accordance with AS/NZS 2918:2018.

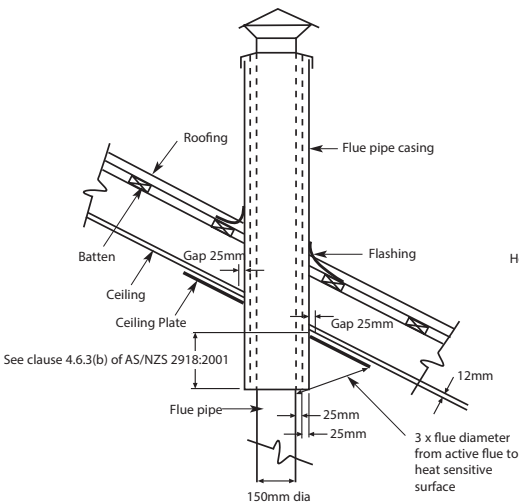
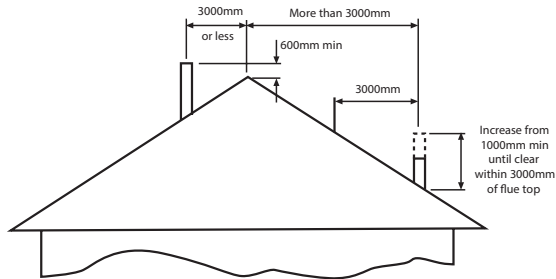
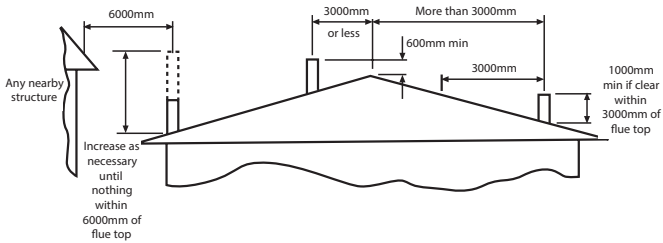

Example of sloped ceiling penetration

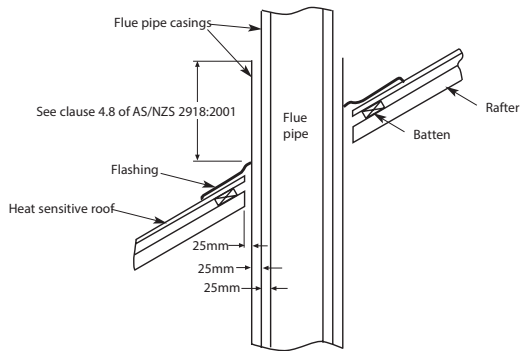

Example of roof penetration

Operating your Jindara woodheater



WARNING

Read these instructions

DO NOT ATTEMPT TO OPERATE THIS APPLIANCE WITHOUT READING AND UNDERSTANDING THESE OPERATING INSTRUCTIONS THOROUGHLY. FAILURE TO OPERATE THIS APPLIANCE PROPERLY MAY CAUSE UNDUE DAMAGE TO THE APPLIANCE OR RESULT IN A FLUE FIRE.

Starting your fire

Place a firelighter or paper in the bottom of the firebox and place a large amount of small kindling on top. Ignite the paper or the firelighter. Set the air control to high and leave the main door open approximately 25mm. When the kindling is burning, place about four pieces of small wood on top of the burning kindling. Once the wood is alight, close the main door. After approximately 20 minutes, turn the air control down to Medium and turn the fan on to Low speed.

On the initial fire-up you may detect smoke coming from the paint finish and from any oils that may be on the steel on the outside of the firebox. This is normal. It is suggested to well ventilate your home on the initial fire up. Please refer to our section 'Paint Curing and Care'.

The glass door

Always operate your heater with the door closed and locked. The only time you can leave the door open is on initial lighting, or when reloading the heater.

Care of your glass

If you are burning good dry hardwood, you will have very little discolouration of your glass in a normal burning cycle. If you aim for an overnight burn, you should not get much discolouration. You can control this by adjusting the air control, moving from the left and slowly creeping the control to the right. After a number of days you will find the right position to suit your requirements and the fuel that you are using.

Cleaning the glass

Generally the only time you will possibly need to clean your glass is after a long overnight burn. If you find that you have a wet sticky black film on your glass (creosote), it is better to burn the heater as normal for one load of wood. When the wood has burnt down to a hot bed of embers, open the door and leave it wide open until the glass cools sufficiently to be wiped with a damp cloth. This should clean all the white smoky film off the glass. Creosote on the glass is normally a sign that you have tried to get too long an overnight burn or you have burnt excessively wet or green wood. If the film on the glass won't come off with a wet cloth, you can use wet ash from the ash bed as a cleaner or commercial products such as Crystal Clear, Johnson Foam Clean or Windex.

Normal operations

When you get up in the morning, open up the air control of the heater to High position to start the embers glowing. Place some wood on top of the embers and leave the door open 25mm. Once the fuel starts to flame close the door. As the heater starts to heat up turn the fan on to Low, (approx 20 minutes) and begin reducing the air control towards a lower setting.

The fan

You will find with the fan on Low you will only need to run the heater between the Low and Medium air control setting to maintain the temperature you desire in your home. To obtain the maximum heat dissipation from the heater it is necessary to run the fan at any time the heater is running above the Low position.

For best results it is best to burn 300mm long wood and load your wood straight into the firebox front to rear. This will give optimum efficiency and recoverable heat, and minimise creosote formation and smoke emissions.

Overnight burn

Approximately 30 minutes before turning the heater down to overnight burn it is recommended to load the heater with fuel for the overnight burn. Leave the air control in the Medium to High position. Let the heater run for about thirty minutes. This will reduce the moisture content in the fuel before shut down. (This will help reduce the creosote formation in the firebox and flue.) Set the air control to the setting you have found best for your requirements. Turn the fan off and retire. The aim when overnight burning is to have only a few hot embers left in the bottom of the firebox in the morning, not huge lumps of wood.

Operating your Jindara wood heater (continued)

Cleaning your flue

Carefully remove the baffle plate, cast iron plates, ash deflector and fire bricks and put them to one side. Close the heater door. Obtain a 150mm flue brush from your local Jindara dealer and proceed up onto the roof. Remove the cowl.

Slowly push the flue brush down the chimney until it stops.

Pull the brush back out and repeat the process. Each time you do this you will notice that the brush will go further down the chimney till it reaches the bottom. The soot and creosote will fall down the chimney and into the firebox. Clean residue from the firebox. Replace all parts. Make sure you do the job well. The cleaner the flue the less chance there will be of the creosote sticking again. After you have replaced the cowl, inspect the roof flashing for any damage that may have been incurred whilst you were cleaning the flue. Reseal the seal on the roof with roof and gutter silicone if required.

The fan

It is recommended to run the fan while the heater is operating above Low burn on Low speed. For extended periods when the heater is running above medium fire, High or Boost is recommended. Boost is recommended for short bursts where a quick temperature rise is desired in conjunction with a high fire setting. The fan should be cleaned on a regular basis. (Refer Troubleshooting for fan removal and cleaning.)

Door handle adjustment

When the door gasket become loose and leaking occurs it is necessary to adjust the door handle.

- Ensure heater is cold – open door.
- Undo M20 locknut, note that roll pin may need to be offset.
- Unscrew hex head screw in door handle shaft.
- Rotate handle shaft anti-clockwise – 1 turn = 1 millimetre of adjustment.
- Replace M20 locknut.
- Centralize roll pin.
- Close door, engaging handle to check for seal .
- Trying to rip a small piece of paper inbetween door rope and firebox will help determine if sealing is sufficient. If paper is removed without resistance, repeat adjustment process until resistance is achieved.
- Replace hex head screw when adjustment process in complete.



WARNING

Operation of the fan

If firebox failure is reported and it is found that the firebox has been abused through improper use of the fan, Jindara reserves the right to disallow any warranty claims in relation to firebox failure.



WARNING

The Door

Leaving Door Open

As stated previously in relation to leaving the door open 25mm to encourage the fire to pick up at a faster rate, your heater has been tested to ensure that no structural damage can take place if the door is inadvertently left open. However your paint finish can be damaged if the door is left open for a long period with a full firebox of fuel with the fan off. Closely supervise your heater while the door is left open.

Closing the Door

Always ensure that before you close your door there is no wood protruding beyond the front of the firebox opening. Do not use the door glass as a 'battering ram' to push the wood back into the firebox. Damage to the glass by such impact is not covered by your Warranty.

Troubleshooting

- **Noisy fan**

Turn the power off and remove the three pin plug from the power point.

Remove the two screws that hold the front fan access panel. Remove the panel.

Disconnect the wiring loom via the plastic joiner. Unscrew the two nuts which hold the fan in position and remove the fan. Clean any dust with a dry paint brush and vacuum the fan blades. Clean around the motor. After completion place two or three drops of sewing machine oil on the shafts at the bearings. Replace the fan in reverse to the removal.

- **Fan not working**

Check the power connection with another appliance. If the power point is okay assume the fan or the switch is defective. Isolate the power as above. Check that the terminals on the loom and the switch are firmly connected. If the fan then fails to function, remove the fan and switch by firstly removing the knob off the fan switch by pulling it away from the heater. Undo the holding nut and pull the switch out. Disconnect the wiring from the power lead and remove the fan and switch. Convey the same to the authorised Jindara dealer from whom you purchased your unit for service. Replace in the reverse order.

- **Air control jamming**

Lift up and remove the top plate.

Remove the air control knob by turning anti-clockwise. Lift the air control panel out of the way.

There are three bolts holding the air slide in place. Undo them and remove the air slide. Wipe any ash or dust that may have accumulated on the back of the air slide or on the face of the heater. If any burrs have developed on the back of the air slide or on the face of the heater, rub them off with fine wet and dry sand paper till you have a smooth surface and edges. Replace the air slide and make sure the washers, spacers and springs are on the bolts when you screw the bolts back into the face of the heater. Do not apply any type of lubricant to the air slide whatsoever as this will attract dust and make the slide stick.

- **No overnight burn**

Remove the air slide as per air control jamming and check that the air slide is hard against the face of the heater. If it is loose, tighten up the bolts holding the air slide to the face of the heater. Do not overtighten.

Check that the door rope has an even indentation from the sealing strip, which is on the face of the firebox. If it is uneven and it appears as though air could leak through the seal, adjust the thickness of the door rope to suit. Stretch the rope to make it thinner where the indentation is the heaviest and bunch up the excess where the indentation is smaller.

The door may become loose through the door seal shrinking. Refer "Door handle adjustment" instructions on page 8.



WARNING

Overfiring

NEVER OPERATE THE HEATER WITH THE DOOR LOOSE OR NOT AIR TIGHT.
OVERFIRING COULD RESULT IN DETRIMENTAL WEAR AND TEAR ON THE FIREBOX.

Troubleshooting (continued)

- **Smoke entering the room from the firebox when the door is open may be caused by**

- Insufficient length of flue (flue to be 4500mm minimum underneath the base of heater to underside of cowl)
Increase height of flue
- Flue downdraught
Consult dealer or increase height of flue.
- Creosote buildup in flue
Remove cowl and clean flue as per cleaning instructions. Check moisture content of wood.

- **Excessive ash build up**

Some woods will give large amounts of ash despite how you run the heater. Others will give you very little. Use the wood which is most convenient for you as long as it is dry. After a period of time you will get to know when to empty your unit. Bark will give you excessive ash. Try not to burn it.

If you are burning wood that gives you charcoal, you may find that after running the heater say for 8 hours at maximum burn rate, the charcoal builds up excessively. Overnight burn will reduce this charcoal back to a fine ash. If you are not ready to shut down for overnight burn when you next fuel the stove, load the stove with only one piece of wood and lay it across the firebox on top of the charcoal. Open the air control wide open and you will find the charcoal will burn down with the one piece of wood. Repeat the process until the ash level is significantly reduced.

PAGE INTENTIONALLY BLANK

WARRANTY

1. Subject to clauses 2 & 3 of this Warranty, A.F. Gason Pty Ltd ACN 004 667 556 (Gason) warrants the following components of its heaters against defects in workmanship and/or materials for the following periods from the date of purchase:
 - a) the firebox for ten years;
 - b) the paint finish for a period of twelve months if the Purchaser has followed the instructions provided by Gason in the Operation and Installation Instructions manual; and
 - c) all other components for twelve months except the glass, fire brick lining or baffle plate if, in the opinion of Gason, these items have been damaged by impact.
2. This extended warranty does not apply:
 - a) if the heater is purchased from a person who has not been authorised by Gason to sell its products;
 - b) if, in the opinion of Gason, the heater or any other component has been subject to abuse, misuse, alteration, modification or has not been installed, operated or maintained in accordance with the instructions provided by Gason; or,
 - c) to owners other than the original Purchaser.
3. If you believe that the heater you purchased contains a manufacturing defect and you wish to make a claim under this Warranty, please contact an authorised Gason service centre to arrange for an assessment.
 4. If, after assessing the heater, Gason determines that the heater contains a manufacturing fault, Gason may at its discretion:
 - a) replace the heater;
 - b) repair or replace specific components of the heater; or
 - c) provide a full refund.
 5. Parts replaced under warranty are warranted for the balance of their original warranty period.
 6. If, at the discretion of Gason, the heater or any part needs to be replaced, serviced or repaired at an authorised Gason service centre, then the person claiming under this Warranty must pay all costs associated with:
 - a) returning the heater; and
 - b) the delivery or collection of any new or repaired heater.

Our goods come with guarantees that cannot be excluded under the Australian Consumer Law. You are entitled to a replacement or refund for a major failure and for compensation for any other reasonably foreseeable loss or damage. You are also entitled to have the goods repaired or replaced if the goods fail to be of acceptable quality and the failure does not amount to a major failure.

Any benefits you receive under these warranties are in addition to other rights and remedies that you may have as a consumer under a law in relation to the heater to which these warranties relate.

These warranties are given by:

A.F. Gason Pty. Ltd.
 Blake Street
 Ararat VIC 3377

Please contact us if you have any queries on:

Phone: 03 97632700

or email us via the "Contact Us" section of our website: www.gason.com.au

A.F. Gason Pty Ltd reserves the right to modify or alter specifications, material etc. in the interest of product improvement